

Max-Planck-Institut
für Mathematik
in den Naturwissenschaften
Leipzig

Oriented shadowing property and Ω -stability for
vector fields

by

Shaobo Gan, Ming Li, and Sergey Tikhomirov

Preprint no.: 48

2014



ORIENTED SHADOWING PROPERTY AND Ω -STABILITY FOR VECTOR FIELDS

SHAOBO GAN, MING LI, AND SERGEY B. TIKHOMIROV

ABSTRACT. We call that a vector field has the oriented shadowing property if for any $\varepsilon > 0$ there is $d > 0$ such that each d -pseudo orbit is ε -oriented shadowed by some real orbit. In this paper, we show that the C^1 -interior of the set of vector fields with the oriented shadowing property is contained in the set of vector fields with the Ω -stability.

1. INTRODUCTION

The theory of shadowing of approximate trajectories (pseudo orbits or pseudo-trajectories) of dynamical systems is now a well developed part of the global theory of dynamical systems (see, for example, the monographs [16, 19]). This theory is closely related to the classical theory of structural stability (the basic definitions of structural stability and Ω -stability for diffeomorphisms and vector fields can be found, for example, in the monograph [18, 8]).

It is well known that a diffeomorphism has the shadowing property in a neighborhood of a hyperbolic set [1, 3] and a structurally stable diffeomorphism (satisfying Axioma A and the strong transversality condition) has the shadowing property on the whole manifold [25, 15, 27]. At the same time, the problem of complete description of systems having the shadowing property seems unsolvable. We have no hope to characterize systems with the shadowing property in terms of the theory of structural stability (such as hyperbolicity and transversality) since the shadowing property is preserved under homeomorphisms of the phase space (at least in the compact case), while the above-mentioned properties are not.

The situation changes completely when we pass from the set of smooth dynamical systems having the shadowing property to its C^1 -interior. It was shown by Sakai [26] that the C^1 -interior of the set of diffeomorphisms with the shadowing property coincides with the set of structurally stable diffeomorphisms (see [21] for some generalizations).

In the present paper we study C^1 -interior of the set of vector fields with the shadowing property (we call them vector fields with the robust shadowing property). Let us note that the main difference between the shadowing problem for flows and the similar problem for discrete dynamical systems generated by diffeomorphisms is related to the necessity of reparametrization of shadowing trajectories in the former case. Another difference arises because of the possibility of accumulation of periodic orbits to a singularity in a robust way.

As in the case of diffeomorphisms, it is well known that a vector field has the shadowing property in a neighborhood of a hyperbolic set [16, 19] and a structurally

2000 *Mathematics Subject Classification.* Primary 37C50.

Key words and phrases. Vector fields; oriented shadowing; Ω -stability.

stable vector field (satisfying Axiom A' and the strong transversality condition) has the shadowing property on the whole manifold [19, 20]. And as with diffeomorphisms, structural stability is not equivalent to shadowing.

The structure of the C^1 -interior of the set of vector fields with the shadowing property is more complicated.

A lot of results show deep connection between C^1 -interior of the set of vector fields with the shadowing property and structural stability. For vector fields without singularities such C^1 -interior consists only from structurally stable vector fields [10]. On manifolds of dimension 3 and less such C^1 -interior coincides with the set of structurally stable vector fields [30, 22]. Vector fields with the robust shadowing property and without nontransverse intersection stable and unstable manifolds of two hyperbolic singularities are structurally stable [22, 23].

At the same time there exists a non-structurally stable vector field on a manifold of dimension 4 which lies in the C^1 -interior of the set of vector fields with the shadowing property [23]. The example is a semi-local construction, which consists of two hyperbolic singularities points with complex conjugated eigenvalues and a trajectory of non-transverse intersection of their stable and unstable manifolds. In this example the vector field is not structurally stable due to failure of the strong transversality condition. However it is not clear if one can construct a vector field with the robust shadowing property, which does not satisfy Axiom A'.

In present work we prove that vector fields with the robust shadowing property are Ω -stable and hence satisfy Axiom A'.

The key role in the proof plays the star condition (which means that one can not get non-hyperbolic singularities or closed trajectories via a C^1 small perturbation, see section 3 for the details). For diffeomorphisms, it is proved in [2, 7, 13, 14] that the star condition implies the Ω -stability. However, it is not true for vector fields [4, 6, 11]. So we have to use additional arguments (Lemmas 3.5, 4.1) in order to prove Ω -stability.

It is worth to mention another approach to compare shadowing and structural stability. Analyzing the proofs of the first shadowing results by Anosov [1] and Bowen [3], it is easy to see that, in a neighborhood of a hyperbolic set, the shadowing property is Lipschitz (and the same holds in the case of structurally stable diffeomorphisms and vector fields [19]). Moreover structural stability is equivalent to Lipschitz shadowing for diffeomorphisms [24], and vector fields [17].

The paper is organised as follows. In section 2 we give necessary definitions and state the main result. In section 3 we define notion of star flows and formulate necessary statements about them. In section 4 we formulate key Lemma 4.1 and reduce the main theorem to it. In section 5 we prove some properties of a vector field in a neighborhood of a singularity with a homoclinic connection. In section 6 we complete the proof of Lemma 4.1.

2. DEFINITIONS AND MAIN RESULTS

Let M be a compact smooth Riemannian manifold without boundary. Denote by $\mathcal{X}^1(M)$ the set of C^1 vector fields on M endowed with the C^1 -topology. For a set $A \subset \mathcal{X}^1(M)$ denote $\text{Int}^1(A)$ the interior of A in the C^1 -topology.

For any $X \in \mathcal{X}^1(M)$, X generates a C^1 flow

$$\phi_t = \phi_{X,t} : M \rightarrow M, t \in \mathbb{R}.$$

Let

$$\text{Sing}(X) = \{x \in M : X(x) = 0\}$$

be the set of singularities of X and

$$\text{Per}(X) = \{x \in M \setminus \text{Sing}(X) : \exists T \text{ such that } \phi_T(x) = x\}$$

be the set of regular periodic points of X . (Here we say a point is *regular* if it is not a singularity.)

Denote by $\text{Orb}(x) = \text{Orb}_X(x) = \phi_{(-\infty, +\infty)}(x)$ the orbit of x . And denote by $\text{Orb}^+(x) = \phi_{[0, +\infty)}(x)$, $\text{Orb}^-(x) = \phi_{(-\infty, 0]}(x)$ the forward, negative orbit of x respectively.

For any $d > 0$, a map $g : \mathbb{R} \rightarrow M$ (not necessarily continuous) is called a *d-pseudo orbit*, if

$$\text{dist}(g(t + \tau), \phi_\tau(g(t))) < d$$

for all $t \in \mathbb{R}$ and $\tau \in [0, 1]$.

A reparametrization is an increasing homeomorphism h of the line \mathbb{R} such that $h(0) = 0$; we denote by Rep the set of all reparametrizations. For $a > 0$, we denote

$$\text{Rep}(a) = \left\{ h \in \text{Rep} : \left| \frac{h(t) - h(s)}{t - s} - 1 \right| < a, \quad t, s \in \mathbb{R}, t \neq s \right\}.$$

We say that a vector field $X \in \mathcal{X}^1(M)$ has the (*standard*) *shadowing property* if for any $\varepsilon > 0$ there exists a constant $d > 0$ such that, for any d -pseudo orbit g of X , g is ε -shadowed by a real orbit of X , that is, there exists a point $x \in M$ and a reparametrization $h \in \text{Rep}(\varepsilon)$ satisfying

$$(2.1) \quad \text{dist}(g(t), \phi_{h(t)}(x)) \leq \varepsilon, \quad \text{for all } t.$$

Denote by $\text{StSh}(M)$ the set of vector fields satisfying the shadowing property.

We say that a vector field $X \in \mathcal{X}^1(M)$ has the *oriented shadowing property* if for any $\varepsilon > 0$ there exists a constant $d > 0$ such that, for any d -pseudo orbit g of X , g is ε -oriented shadowed by a real orbit of X , that is, there exists a point $x \in M$ and a reparametrization $h \in \text{Rep}$ satisfying (2.1). Denote by $\text{OrientSh}(M)$ the set of vector fields satisfying the oriented shadowing property. Moreover, we say that a vector field X has the *C^1 -robustly oriented shadowing property* if $X \in \text{Int}^1(\text{OrientSh}(M))$.

Let us note that the standard shadowing property is equivalent to the strong pseudo orbit tracing property (POTP) in the sense of Komuro [9]; the oriented shadowing property was called the normal POTP by Komuro [9] and the POTP for flows by Thomas [29]. Clearly

$$(2.2) \quad \text{StSh}(M) \subset \text{OrientSh}(M).$$

Recently it was shown that the difference in the choice of reparametrization is essential, so inclusion (2.2) is strict [31].

In the present paper we consider oriented shadowing property. Below is the main result of this paper.

Theorem 2.1. *Every vector field satisfying the C^1 -robustly oriented shadowing property is Ω -stable.*

3. STAR VECTOR FIELDS

In the proofs we need some results about star vector fields. Recall that a vector field $X \in \mathcal{X}^1(M)$ is a *star vector field* on M if X has a C^1 neighborhood \mathcal{U} in $\mathcal{X}^1(M)$ such that, for every $Y \in \mathcal{U}$, every singularity of Y and every periodic orbit of Y is hyperbolic. Denote by $\mathcal{X}^*(M)$ the set of star vector fields on M .

It was proved in [23] that every vector field satisfying the C^1 -robustly oriented shadowing property is a star vector field.

Lemma 3.1. $\text{Int}^1(\text{OrientSh}(M)) \subset \mathcal{X}^*(M)$.

We say that a point $x \in M$ is *preperiodic* of X , if for any C^1 neighborhood \mathcal{U} of X in $\mathcal{X}^1(M)$ and any neighborhood U of x in M , there exists $Y \in \mathcal{U}$ and $y \in U$ such that y is a regular periodic point of Y . Denote by $\text{Per}_*(X)$ the set of preperiodic points of X . We will use the following result which is proved in [5].

Theorem 3.2. *Let $X \in \mathcal{X}^*(M)$. If $\text{Sing}(X) \cap \text{Per}_*(X) = \emptyset$, then X is Ω -stable.*

We also need some results about the dominated splitting in the tangent space of singularities. Denote by

$$\text{Re}(\lambda_s) \leq \dots \leq \text{Re}(\lambda_2) \leq \text{Re}(\lambda_1) < 0 < \text{Re}(\gamma_1) \leq \text{Re}(\gamma_2) \leq \dots \leq \text{Re}(\gamma_u),$$

the eigenvalues of $\text{DX}(\sigma)$. The *saddle value* of σ is

$$\text{SV}(\sigma) = \text{Re}(\lambda_1) + \text{Re}(\gamma_1).$$

We write $\text{Ind}(\sigma)$ the *index* of a hyperbolic singularity $\sigma \in \text{Sing}(X)$ which is the dimension of the stable manifold of σ . We write $\text{Ind}(p)$ the *index* of a regular hyperbolic periodic point $p \in \text{Per}(X)$ which is the dimension of the strong stable manifold of p .

Recall that a *homoclinic connection* Γ of a singularity σ is the closure of an orbit of a regular point which is contained in both the stable and the unstable manifolds of σ . The following lemma is a simplified version of results in [28].

Lemma 3.3. *Let $\sigma \in \text{Sing}(X)$ be a singularity of vector field $X \in \mathcal{X}^1(X)$ exhibiting a homoclinic connection Γ . If $\text{SV}(\sigma) \geq 0$, then for any C^1 neighborhood \mathcal{U} of X in $\mathcal{X}^1(M)$ and any neighborhood U of Γ in M , there exists $Y \in \mathcal{U}$ and $p \in \text{Per}(Y)$ such that $\text{Orb}_Y(p) \subset U$ and $\text{Ind}(p) = \text{Ind}(\sigma) - 1$.*

By using the same argument in the proof of [12, Lemma 4.1], we can get:

Lemma 3.4. *Let $X \in \mathcal{X}^*(M)$ and $\sigma \in \text{Sing}(X)$ be a singularity of X . If there exists a integer $1 \leq I \leq \text{Ind}(\sigma) - 1$ such that, for any C^1 neighborhood \mathcal{U} of X in $\mathcal{X}^*(M)$ and any neighborhood U of σ in M , there exists $Y \in \mathcal{U}$ and $p \in U \cap \text{Per}(Y)$ with $\text{Ind}(p) = I$. Then E_σ^s splits into a dominated splitting*

$$E_\sigma^s = E_\sigma^{ss} \oplus E_\sigma^c,$$

where $\dim E_\sigma^{ss} = I$.

Combined Lemma 3.3 with Lemma 3.4, we obtain directly the following lemma about singularities of star vector fields exhibiting a homoclinic connection.

Lemma 3.5. *Let $X \in \mathcal{X}^*(M)$ be a star vector field and $\sigma \in \text{Sing}(X)$ be a singularity of X exhibiting a homoclinic connection.*

- If $SV(\sigma) \geq 0$ and $\dim E_\sigma^s \geq 2$, then E_σ^s splits into a dominated splitting

$$E_\sigma^s = E_\sigma^{ss} \oplus E_\sigma^c,$$

where $\dim E_\sigma^c = 1$;

- If $SV(\sigma) \leq 0$ and $\dim E_\sigma^u \geq 2$, then E_σ^u splits into a dominated splitting

$$E_\sigma^u = E_\sigma^c \oplus E_\sigma^{uu},$$

where $\dim E_\sigma^c = 1$.

4. PROOF OF THEOREM 2.1

The key step of the proof is the following lemma, which will be proved in the next sections.

Lemma 4.1. *Let $X \in \mathcal{X}^*(M)$. If there exists a singularity $\sigma \in \text{Sing}(X)$ exhibiting a homoclinic connection, then $X \notin \text{Int}^1(\text{OrientSh}(M))$.*

Now Theorem 2.1 is a consequence of Lemmas 3.1, 4.1 and Theorem 3.2. Indeed,

Proof of Theorem 2.1. On the contrary, suppose that there exists a vector field $X \in \text{Int}^1(\text{OrientSh}(M))$ satisfying the C^1 -robustly oriented shadowing property which is not Ω -stable. By Lemma 3.1 we know that $X \in \mathcal{X}^*(M)$ is a star vector field. Since X is not Ω -stable, we have that $\text{Sing}(X) \cap \text{Per}_*(X) \neq \emptyset$ according to Theorem 3.2. Suppose that $\sigma \in \text{Sing}(X) \cap \text{Per}_*(X)$ is a preperiodic singularity. Note that σ is a hyperbolic saddle type singularity.

Since σ is preperiodic, there exists a vector field Y arbitrarily C^1 close to X and a regular periodic point of Y whose orbit is arbitrarily close to the local stable and local unstable manifolds of σ_Y , where σ_Y is the continuation of σ . Then by using the connecting Lemma (see [32] for instance), we can get a vector field Z exhibiting a homoclinic connection

$$\Gamma \subset W^{s,Z}(\sigma_z) \cap W^{u,Z}(\sigma_z).$$

Note that this perturbation can be made arbitrarily C^1 small. Thus we may still have $Z \in \text{Int}^1(\text{OrientSh}(M))$. It contradicts with Lemma 4.1. \square

The rest part of the paper is devoted to the proof of Lemma 4.1. It follows the strategy similar to [23, Section 2, Case (B1)].

5. LOCAL LINEAR MODEL OF HOMOCLINIC CONNECTION

In this section, we will consider a local linear model of a singularity exhibiting a homoclinic connection. Let $\sigma \in \text{Sing}(X)$ be a saddle type hyperbolic singularity of X and

$$\Gamma \subset W^s(\sigma) \cap W^u(\sigma)$$

be a homoclinic connection of σ . Denote by $s = \dim E_\sigma^s$, $u = \dim E_\sigma^u$ the dimension of contracting and expanding subspaces of σ .

In this section we assume that X satisfies the following

- Condition 5.1.**
- X is linear in a small neighborhood $U(\sigma)$ of σ ;
 - $s \geq 2$ and there exists a dominated splitting $E_\sigma^s = E_\sigma^{ss} \oplus E_\sigma^c$, where $\dim E_\sigma^c = 1$;
 - $\{E_\sigma^{ss}, E_\sigma^c, E_\sigma^u\}$ are mutually orthogonal;

- $\Gamma \cap W^{ss}(\sigma) = \{\sigma\}$, where $W^{ss}(\sigma)$ is the strong stable manifold which is tangent to E_σ^{ss} .

We introduce a orthogonal coordinate system (x^{ss}, x^c, x^u) with respect to the splitting

$$T_\sigma M = E_\sigma^{ss} \oplus E_\sigma^c \oplus E_\sigma^u$$

in the neighborhood $U(\sigma)$, where x^{ss}, x^c, x^u are the coordinates of $x \in U(\sigma)$ in $E_\sigma^{ss}, E_\sigma^c, E_\sigma^u$ respectively.

We take two points $O_s = (O_s^{ss}, O_s^c, 0), O_u = (0, 0, O_u^u) \in \Gamma \cap U(\sigma) \setminus \{\sigma\}$ contained in E_σ^s and E_σ^u respectively. Note that $O_s^c \neq 0$ since $\Gamma \cap W^{ss}(\sigma) = \{\sigma\}$. In the neighborhood $U(\sigma)$, we choose a small codimension 1 cross section Σ_s containing O_s which is orthogonal to E_σ^c and another small codimension 1 cross section Σ_u containing O_u which is parallel to E_σ^s .

Denote by $Q : \Sigma_u \rightarrow \Sigma_s$ the Poincaré map from Σ_u to Σ_s , and $\tau_Q(x)$ the minimal positive t such that $\phi_t(x) = Q(x)$. Reduce Σ_u if necessary, we may assume that

$$Q(\overline{\Sigma_u}) \subset \Sigma_s.$$

Thus $\tau_Q(x)$ is bounded for $x \in \Sigma_u$.

Let

$$L_s = \{x \in \Sigma_s : x^u = 0\}$$

be a $(s-1)$ -dimensional disc in Σ_s and

$$L_u = \{x \in \Sigma_u : x^{ss} = 0\}$$

be a u -dimensional disc in Σ_u .

We point that $L_s = W_{loc}^s(\sigma) \cap \Sigma_s$, where $W_{loc}^s(\sigma)$ is the local stable manifold of σ . Since

$$\dim \Sigma_s = \dim M - 1 = s + u - 1.$$

In what follows we additionally assume

Condition 5.2. $Q(L_u)$ is transverse to L_s at O_s in Σ_s .

For any $\eta \geq 0$, we define a cone in Σ_u :

$$C_\eta^u = \{x \in \Sigma_u : |x^{ss}| \leq \eta |x^c|\}.$$

We have the following lemma. (See Figure 1.)

Lemma 5.3. *There exists a positive constant $\beta > 0$ and a neighborhood $\Sigma_u^0 \subset \Sigma_u$ of O_u in Σ_u such that*

$$Q(C_\beta^u \cap \Sigma_u^0) \cap L_s = \{O_s\}.$$

Proof. Note that $L_u = C_0^u$ and $Q(L_u)$ is transverse to L_s at O_s in Σ_s . Since $\tau_Q(x)$ is bounded for $x \in \Sigma_u$, we can get $\beta > 0$ and $\Sigma_u^0 \subset \Sigma_u$ such that $Q(C_\beta^u \cap \Sigma_u^0) \cap L_s = \{O_s\}$ by the continuity. \square

Denote $O_s^- = (0, -O_s^c, 0)$, and let Σ_s^- be a small codimension 1 cross section in $U(\sigma)$ which is orthogonal to E_σ^c at O_s^- . Denote by $P : \text{Dom}(P) \subset \Sigma_s^- \rightarrow \Sigma_u^0$ the Poincaré map from Σ_s^- to Σ_u^0 in $U(\sigma)$, where

$$\text{Dom}(P) = \{x \in \Sigma_s^- : \exists T > 0 \text{ such that } \phi_T(x) \in \Sigma_u^0 \text{ and } \phi_{[0,T]}(x) \subset U(\sigma)\}$$

the domain of P . Denote by $\tau_P(x)$ the minimal positive t such that $\phi_t(x) = P(x)$.

Since E_σ^{ss} is the strong contracting subspace of σ , we have the following lemma. (See Figure 2)

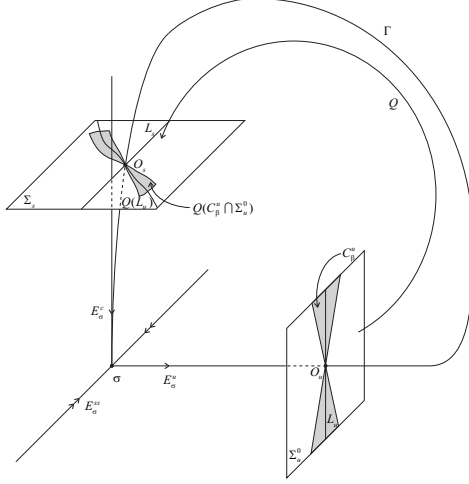

FIGURE 1

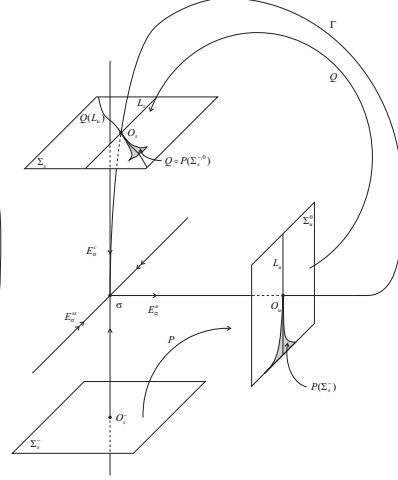

FIGURE 2

Lemma 5.4. *There exists a neighborhood $\Sigma_s^{-,0} \subset \Sigma_s^-$ of O_s^- in Σ_s^- such that, for any $x \in \text{Dom}(P) \cap \Sigma_s^{-,0}$ we have*

$$P(x) \in \mathcal{C}_\beta^u \cap \Sigma_u^0.$$

Proof. Denote by

$$a = \inf\{|x^u| : x \in \Sigma_u^0\} > 0$$

the infimum of the E_σ^u -coordinate of the points in Σ_u^0 and

$$\gamma = \max\{\text{Re}(\alpha) : \alpha \text{ is a eigenvalue of } DX(\sigma)\} > 0$$

the maximum expansion in E_σ^u .

Then for any $x \in \text{Dom}(P)$ (note that $x^u \neq 0$) we have

$$|x^u| e^{\gamma \tau_P(x)} \geq |(P(x))^u| \geq a.$$

It implies that

$$\tau_P(x) \rightarrow +\infty \text{ as } |x^u| \rightarrow 0.$$

On the other hand, since E_σ^{ss} is the strong contracting subspace, we have

$$\frac{|(P(x))^{ss}|}{|(P(x))^c|} \Big/ \frac{|x^{ss}|}{|O_s^c|} = \frac{|(P(x))^{ss}|}{|x^{ss}|} \Big/ \frac{|(P(x))^c|}{|O_s^c|} \rightarrow 0 \text{ as } \tau_P(x) \rightarrow +\infty.$$

Hence $P(x) \in \mathcal{C}_\beta^u$ as $|x^u|$ is small enough. Thus there exists a neighborhood $\Sigma_s^{-,0} \subset \Sigma_s^-$ of O_s^- in Σ_s^- such that

$$P(x) \in \mathcal{C}_\beta^u \cap \Sigma_u^0$$

for any $x \in \Sigma_s^{-,0} \cap \text{Dom}(P)$. \square

Combined Lemma 5.3 and Lemma 5.4, we can get the following lemma immediately.

Lemma 5.5. *For any point $x \in \Sigma_s^{-,0} \cap \text{Dom}(P)$, we have*

$$Q \circ P(x) \notin L^s.$$

\square

6. THE PROOF OF LEMMA 4.1

Suppose on the contrary that there exists a star vector field $X \in \text{Int}^1(\text{OrientSh}(M))$ which has a singularity $\sigma \in \text{Sing}(X)$ exhibiting a homoclinic connection.

Up to an arbitrarily C^1 small perturbation, we may assume that X is linear in a small neighborhood $U_r(\sigma)$ of σ on a proper chart, still exhibits a homoclinic connection $\Gamma \subset W^s(\sigma) \cap W^u(\sigma)$ (see [23] for more details on the perturbations). Without loss of generality, we can assume that $\text{SV}(\sigma) \geq 0$.

We consider the following two cases:

Case 1. $\dim E_\sigma^s = 1$.

In this case, take $\varepsilon = r/10$, then there exists $d > 0$ such that every d -pseudo orbit can be ε -oriented shadowed by a real orbit of X .

Take $p \in W^s(\sigma) \setminus \Gamma$ and $q \in W_{loc}^u(\sigma) \cap \Gamma$ in a small neighborhood of σ such that the map

$$g(t) = \begin{cases} \phi_t(p), & t \leq 0; \\ \phi_t(q), & t > 0. \end{cases}$$

is a d -pseudo orbit. Thus g is ε -oriented shadowed by a real orbit $\text{Orb}(x)$. Note that $q \in W^s(\sigma)$ implies that $x \in W^s(\sigma)$. But since $\dim E_\sigma^s = 1$ we have $x \in \Gamma$. It is a contradiction.

Case 2. $\dim E_\sigma^s \geq 2$.

In this case, by Lemma 3.5 we know that there exists a dominated splitting

$$E_\sigma^s = E_\sigma^{ss} \oplus E_\sigma^c,$$

where $\dim E_\sigma^c = 1$. Changing the Riemannian metric if necessary, we assume that $\{E_\sigma^{ss}, E_\sigma^c, E_\sigma^u\}$ are mutually orthogonal.

By an arbitrarily small perturbation we can find a vector field $X^* \in \text{Int}^1(\text{OrientSh})$, satisfying Conditions 5.1, 5.2. For simplifying the notation we denote it by X again.

Below we are using the notation from section 5.

Let $\beta > 0$ and $\Sigma_s^{-,0} \subset \Sigma_s^-$ be given by Lemma 5.3 and Lemma 5.4. Then for any point $x \in \Sigma_s^{-,0} \cap \text{Dom}(P)$, we have

$$Q \circ P(x) \notin L^s.$$

Take $0 < \varepsilon < \min\{|O_s^c|/10, |O_u^u|/10\}$ small enough such that, for any point x in $U_\varepsilon(O_s)$ ($U_\varepsilon(O_s^-)$, $U_\varepsilon(O_u)$), the component of $\text{Orb}(x)$ in $U_\varepsilon(O_s)$ ($U_\varepsilon(O_s^-)$, $U_\varepsilon(O_u)$) containing x intersects Σ_s ($\Sigma_s^{-,0}$, Σ_u^0).

Let $d > 0$ be the parameter given by the oriented shadowing property according to ε . Since $O_s^- \in W_{loc}^s(\sigma)$ and $O_u \in W_{loc}^u(\sigma)$, there are $p \in \text{Orb}^+(O_s^-)$ and $q \in \text{Orb}^-(O_u)$ in a small neighborhood of σ such that the map

$$g(t) = \begin{cases} \phi_t(p), & t \leq 0; \\ \phi_t(q), & t > 0. \end{cases}$$

is a d -pseudo orbit. Then there exists a point x and an increasing homeomorphism $h(t)$ of the real line such that

$$\text{dist}(g(t), \phi_{h(t)}(x)) \leq \varepsilon$$

for all t .

Denote by t_1 , t_2 and t_3 the parameters satisfying $g(t_1) = O_s^-$, $g(t_2) = O_u$ and $g(t_3) = O_s$. According to the choice of ε , the component of $\text{Orb}(\phi_{h(t_1)}(x))$ ($\text{Orb}(\phi_{h(t_2)}(x))$, $\text{Orb}(\phi_{h(t_3)}(x))$) in $U_\varepsilon(O_s^-)$ ($U_\varepsilon(O_u)$, $U_\varepsilon(O_s)$) would intersect $\Sigma_s^{-,0}$

(Σ_u^0, Σ_s). Denote by $\phi_{h(\tilde{t}_1)}(x)$, $\phi_{h(\tilde{t}_2)}(x)$ and $\phi_{h(\tilde{t}_3)}(x)$ the intersection points respectively.

Since $\text{Orb}(x)$ ε -oriented shadows g , we have that

$$\phi_{h(\tilde{t}_2)}(x) = P(\phi_{h(\tilde{t}_1)}(x)) \quad \text{and} \quad \phi_{h(\tilde{t}_3)}(x) = Q(\phi_{h(\tilde{t}_2)}(x)).$$

Thus by Lemma 5.5, we can get

$$\phi_{h(\tilde{t}_3)}(x) \notin L^s.$$

It implies that $\phi_{h(\tilde{t}_3)}(x) \notin W_{loc}^s(\sigma)$.

But on the other hand, since $O_s = g(t_3) \in W_{loc}^s(\sigma)$ we have

$$\text{Orb}^+(\phi_{h(t_3)}(x)) \subset U_r(\sigma).$$

Thus

$$\text{Orb}^+(\phi_{h(\tilde{t}_3)}(x)) \subset U_r(\sigma).$$

It implies $\phi_{h(\tilde{t}_3)}(x) \in W_{loc}^s(\sigma)$.

This contradiction proves this theorem. \square

ACKNOWLEDGMENT

Shaobo Gan is supported by 973 project 2011CB808002, NSFC 11025101 and 11231001. Ming Li was partially supported by the National Science Foundation of China (Grant No. 11201244), the Specialized Research Fund for the Doctoral Program of Higher Education of China (SRFDP, Grant No. 20120031120024), and the LPMC of Nankai University. Sergey Tikhomirov was partially supported by Chebyshev Laboratory (Department of Mathematics and Mechanics, St. Petersburg State University) under RF Government grant 11.G34.31.0026, JSC ‘‘Gazprom neft’’ and by the St. Petersburg State University in the framework of project 6.38.223.2014.

REFERENCES

1. D.V. Anosov, On a class of invariant sets of smooth dynamical systems, *Proc. 5th Int. Conf. on Nonlin. Oscill.*, vol. 2, Kiev, 1970, 39-45.
2. N. Aoki, The set of Axiom A diffeomorphisms with no cycles, *Bol. Soc. Bras. Mat.*, **23** (1992), 21-65.
3. R. Bowen, *Equilibrium States and the Ergodic Theory of Anosov Diffeomorphisms*, Lecture Notes in Math., vol. 470, Springer, Berlin, 1975.
4. H. Ding, Disturbance of the homoclinic trajectory and applications, *Acta Sci. Nat. Univ. Pekin.*, no. 1 (1986), 53-63.
5. S. Gan, L. Wen, Nonsingular star flows satisfy Axiom A and the no-cycle condition, *Invent. Math.* **164** (2006), 279-315.
6. J. Guckenheimer, *A strange, strange attractor. The Hopf bifurcation theorems and its applications*, Applied Mathematical Series, vol. 19, pp. 368-381, Springer 1976.
7. S. Hayashi, Diffeomorphisms in $\mathcal{F}^1(M)$ satisfy Axiom A, *Ergodic Theory Dyn. Syst.*, **12** (1992), 233C253.
8. A. Katok, B. Hasselblatt, *Introduction to the modern theory of dynamical systems. Encyclopedia of Mathematics and its Applications*, 54. Cambridge University Press, Cambridge, 1995.
9. M. Komuro, One-parameter flows with the pseudo orbit tracing property, *Monat. Math.* **98** (1984), 219-253.
10. K. Lee, K. Sakai, Structural stability of vector fields with shadowing, *J. Differential Equations*, **232** (2007), 303-313.
11. C. Li, L. Wen, \mathcal{A}^* plus Axiom A does not imply no-cycle, *J. Differ. Equations*, **119** (1995), 395C400.

12. M. Li, S. Gan, and L. Wen, Robustly transitive singular sets via approach of an extended linear Poincaré flow, *Discrete Contin. Dyn. Syst.*, **13** (2005), 239-269.
13. S.T. Liao, Obstruction sets (II), *Acta Sci. Nat. Univ. Pekin.*, no. 2 (1981), 1-36.
14. R. Mañé, An ergodic closing lemma, *Ann. Math.*, **116** (1982), 503-540.
15. A. Morimoto, *The method of pseudo-orbit tracing and stability of dynamical systems*, Sem. Note, vol. 39, Tokyo Univ., 1979.
16. K. J. Palmer, *Shadowing in Dynamical Systems: Theory and Applications*, Kluwer, 2000.
17. K. J. Palmer, S. Yu. Pilyugin, S. B. Tikhomirov, Lipschitz shadowing and structural stability of flows, *J. Differential Equations*, **252** (2012), 1723-1747.
18. S. Yu. Pilyugin, *Introduction to Structurally Stable Systems of Differential Equations*, Birkhauser-Verlag, Basel, 1992.
19. S. Yu. Pilyugin, *Shadowing in Dynamical Systems*, Lecture Notes in Math., vol. 1706, Springer, 1999.
20. S. Yu. Pilyugin, Shadowing in structurally stable flows, *J. Diff. Eqns.*, 140, no. 2 (1997) 238-265.
21. S. Yu. Pilyugin, A. A. Rodionova, K. Sakai, Orbital and weak shadowing properties, *Discrete Contin. Dyn. Syst.* **9** (2003), 287-308.
22. S. Yu. Pilyugin, S. B. Tikhomirov, Sets of vector fields with various shadowing properties of pseudotrajectories, *Doklady Mathematics*, **422** (2008), 30-31.
23. S. Yu. Pilyugin, S. B. Tikhomirov, Vector fields with the oriented shadowing property, *J. Differential Equations*, **248** (2010), 1345-1375.
24. S. Yu. Pilyugin, S. B. Tikhomirov, Lipschitz shadowing implies structural stability, *Nonlinearity*, **23** (2010), 2509-2515.
25. C. Robinson, Stability theorems and hyperbolicity in dynamical systems, *Rocky Mountain J. Math.* **7** (1977), 425-437.
26. K. Sakai, Pseudo orbit tracing property and strong transversality of diffeomorphisms on closed manifolds, *Osaka J. Math.* **31** (1994), 373-386.
27. K. Sawada, Extended f -orbits are approximated by orbits, *Nagoya Math. J.* **79** (1980), 33-45.
28. L. P. Shilnikov, A. L. Shilnikov, D. V. Taruve and L. O. Chua, *Methods of qualitative theory in nonlinear dynamics*, World scientific, Series A, vol. 5.
29. R. F. Thomas, Stability properties of one-parameter flows, *Proc. London Math. Soc.*, **54** (1982), 479-505.
30. S.B. Tikhomirov, Interiors of sets of vector fields with shadowing properties that correspond to some classes of reparametrizations, *Vestnik St. Petersburg Univ. Math.*, **41**, no. 4 (2008), 360-366.
31. S. Tikhomirov, An example of a vector field with the oriented shadowing property, <http://arxiv.org/abs/1403.7378>.
32. L. Wen, Z. Xia, C^1 connecting lemmas, *Trans. Amer. Math. Soc.* **352** (2000), 5213-5230.

LMAM AND SCHOOL OF MATHEMATICAL SCIENCES, PEKING UNIVERSITY, BEIJING 100871, PEOPLE'S REPUBLIC OF CHINA

E-mail address: gansb@pku.edu.cn (S. Gan)

SCHOOL OF MATHEMATICAL SCIENCES AND LPMC, NANKAI UNIVERSITY, TIANJIN 300071, PEOPLE'S REPUBLIC OF CHINA

E-mail address: limingmath@nankai.edu.cn (M. Li)

MAX PLANCK INSTITUTE FOR MATHEMATICS IN THE SCIENCES, INSELSTRASSE 22, LEIPZIG, 04103, GERMANY

CHEBYSHEV LABORATORY, SAINT-PETERSBURG STATE UNIVERSITY, 14TH LINE OF VASILIEVSKY ISLAND, 29B, SAINT-PETERSBURG, 199178, RUSSIA

E-mail address: sergey.tikhomirov@gmail.com (S. Tikhomirov)